

WINTTECH®

HMC

4 BAY INSTALLATION GUIDE

CHECKLIST

WINTECH®

4 BAY CONFIGURATION		
CODE	PART LIST	QTY
RF1200/RF900	FRONT PANEL WITH HANDLE & LOCK	1
RF1200/RF900	FRONT PANEL WITH HANDLE	2
RF1200/RF900	FRONT PANEL	1
RF1200/RF900	TOP, BOTTOM PANEL, SHELF, BOTTOM SUPPORT	4
RF1200/RF900	START TRACK	1
RF1200/RF900	JOIN TRACK	1
RF1200/RF900	END TRACK	1
RF1200/RF900	CHIPBOARD	3

WINTECH®

STEP 1 TRACKS INSTALLATION

4 Bay configuration

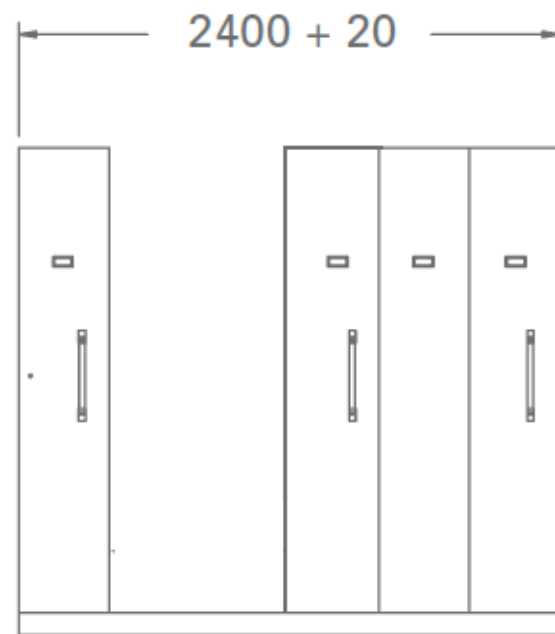

4 BAY

- Lay down and assemble start track
- Install the cross bars to the tracks, take note of the second cross bar, it should be install at the intersection between the start track and join stack which will be install next
- Fit the join caps to the intersection between the start track and join track
- Do not fit in chipboard end cover and end caps as it will be install last

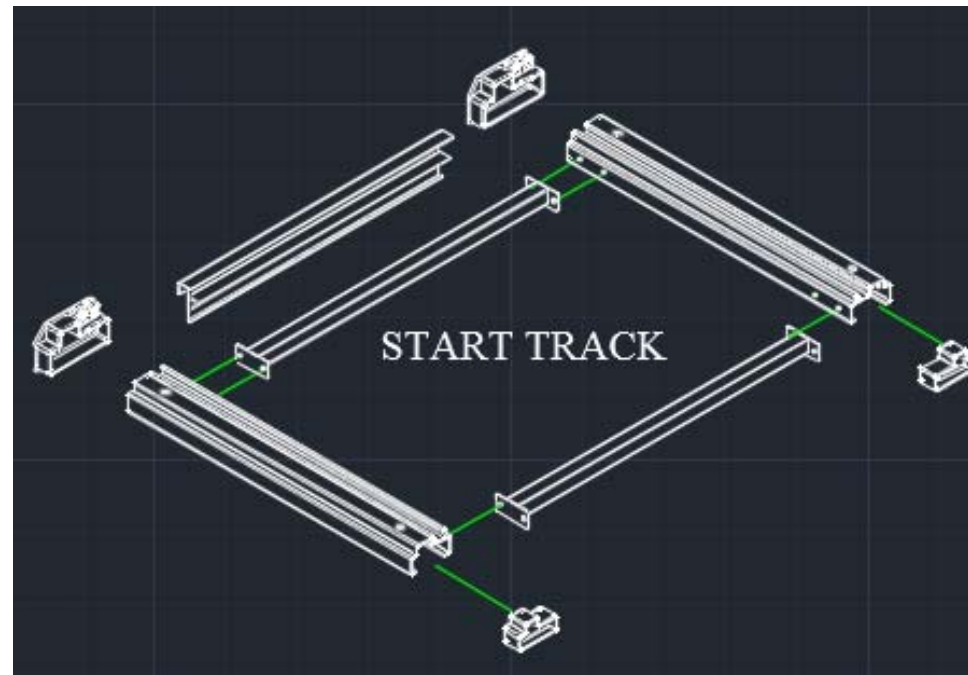

- Slot the join track to the join caps to join start track and join track together
- Install crossbar at the intersection to strengthen the joining of 2 tracks
- Fit the join caps at the other end so that we can join the end track next

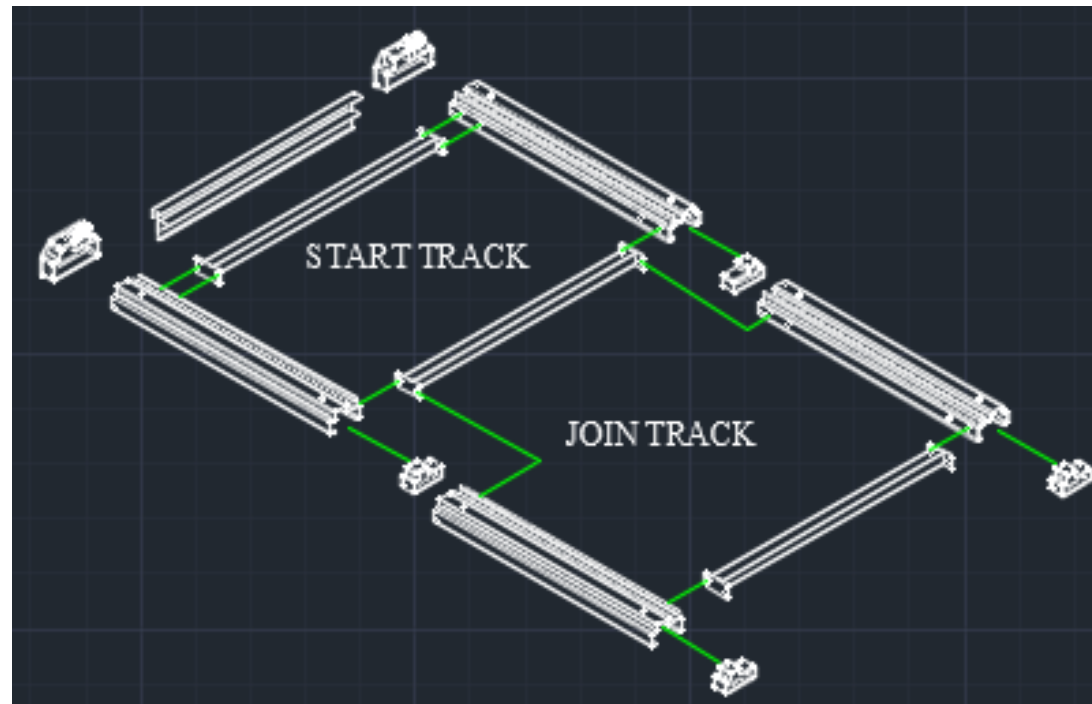

- Slot the end track to the join caps to join start track and end track together
- Install crossbar at the intersection to strengthen the joining of 2 tracks
- Install the second crossbar at the other end
- Do not fit in chipboard end cover and end caps as it will be install last

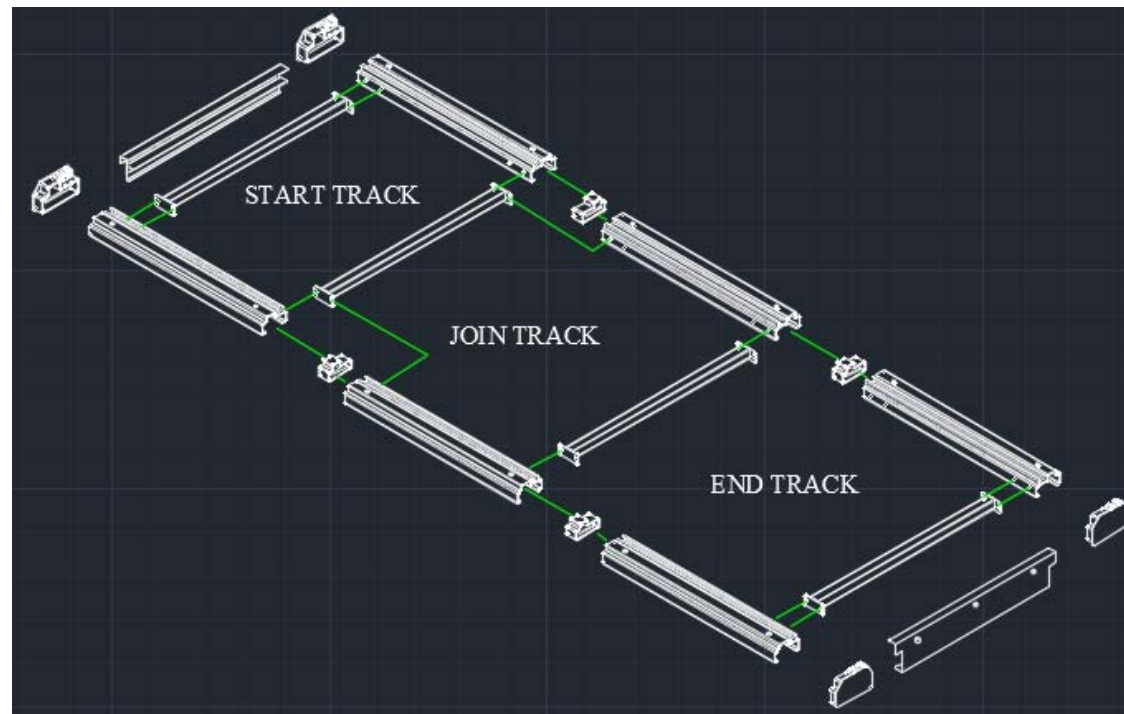

WINTECH®

STEP 2 INTALLING THE SHELVING UNIT

STEP 2

- Assemble the body

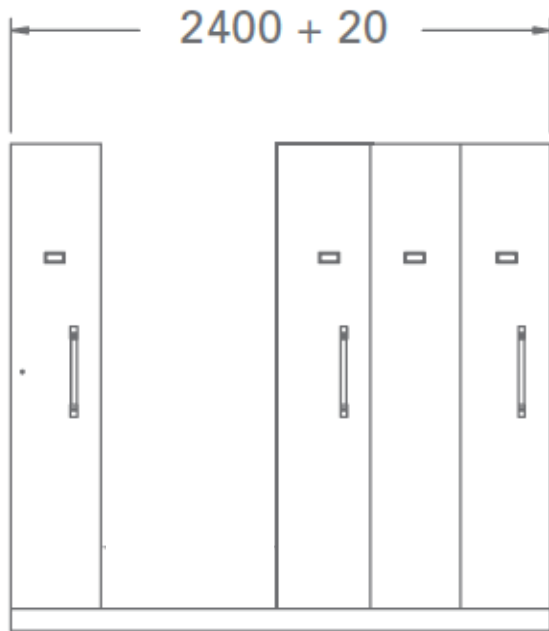

4 BAY

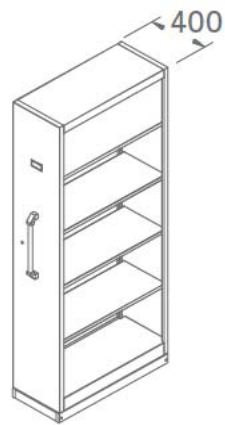

Single Bay
With Lock
(BAY A)

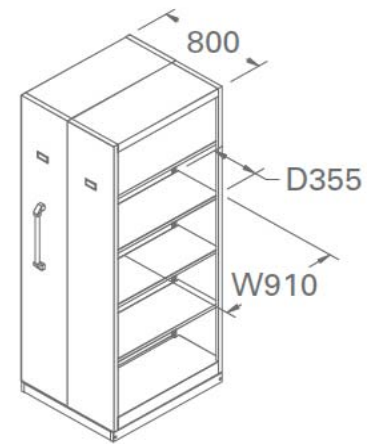

Double bay
(BAY B & C)

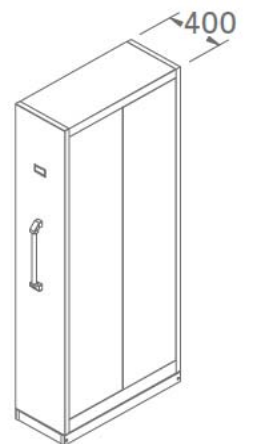

Single bay
(BAY B)

Remember to lie the parts on a flat surface during installation

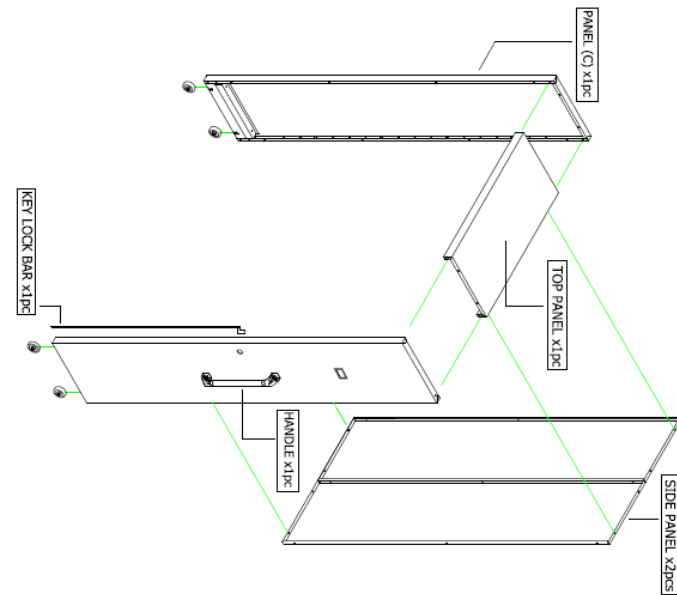
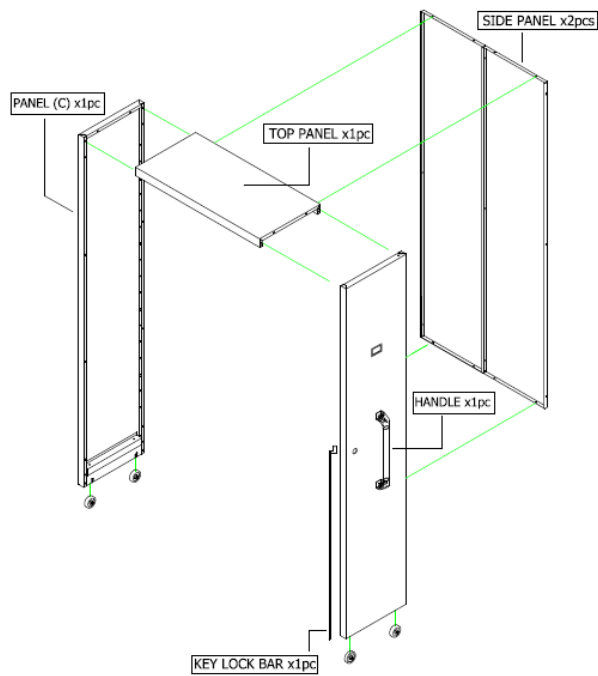

- Join the side panel to the front panel then follow by top panel
- Install handles and lock bar for front panel with handle and lock, handle to front panel with handle only

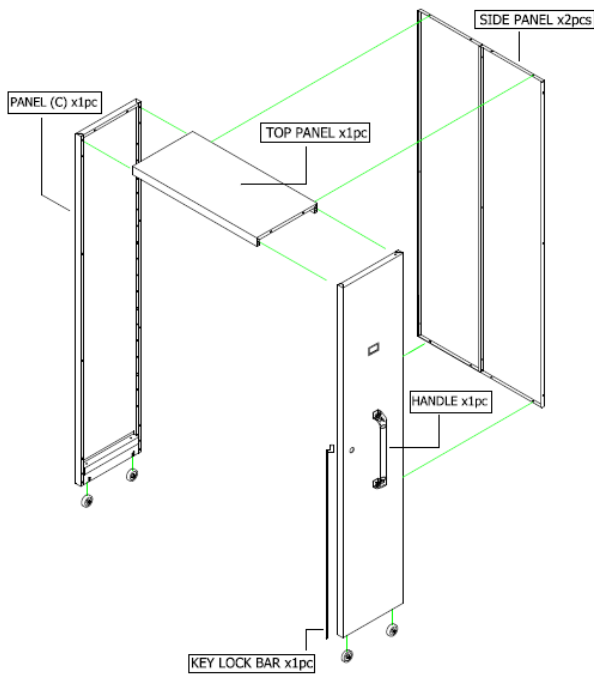

Front panel with handle and lock

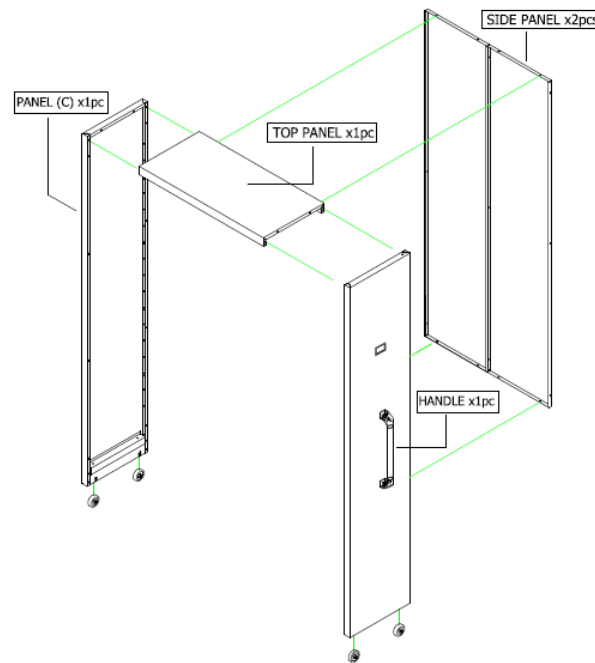

Front panel with handle

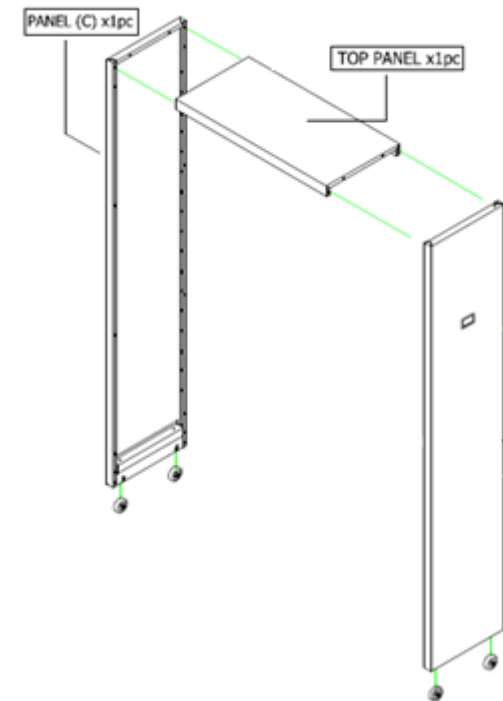

Front panel

- After installing the panels, Install bottom support and bottom shelf
- remember to check whether the wheels are installed to the panels and anti-tilt rollers are installed to the bottom support
- Shelves will be install last

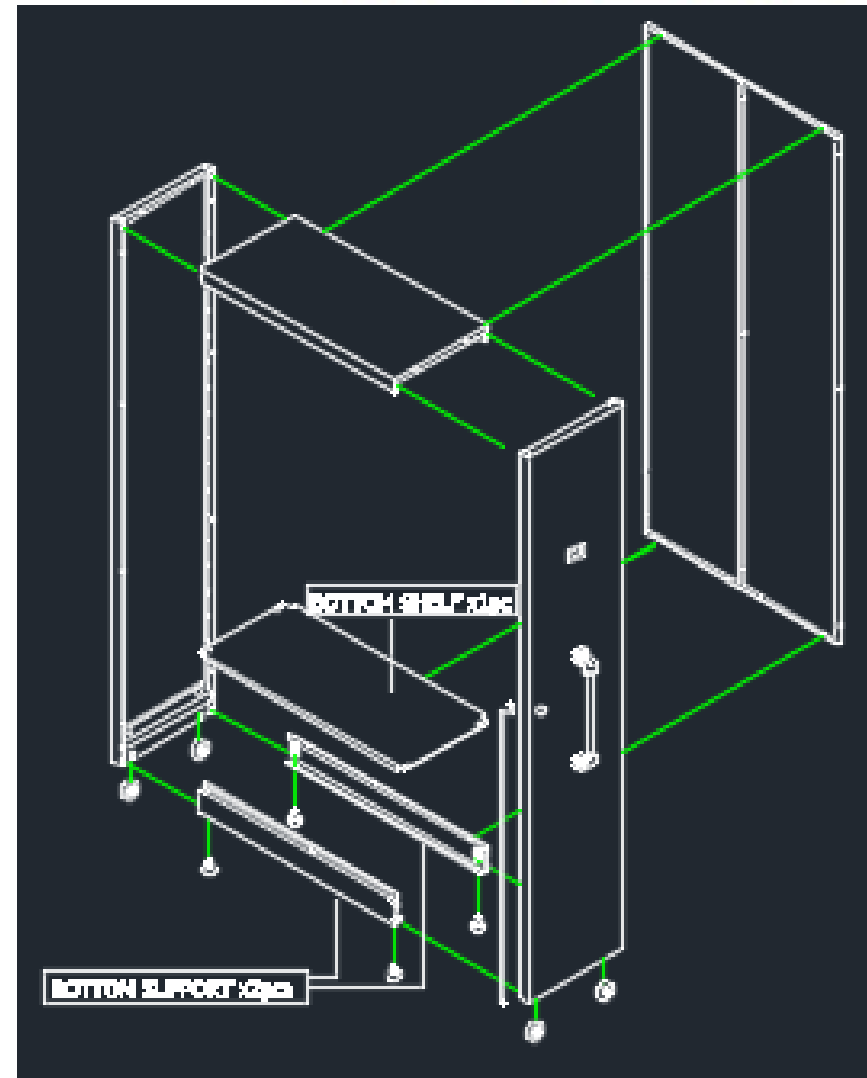

STEP 3 ASSUMBLING THE SHELVING UNIT TO TRACKS

- Once completed, lift up the body carefully and put the body on the tracks
- Slot the anti tilt rollers under the bottom support to the tracks
- Picture show a different type of compactor but the method is the same



Anti tilt rollers under the bottom support



The sequence should be as the following

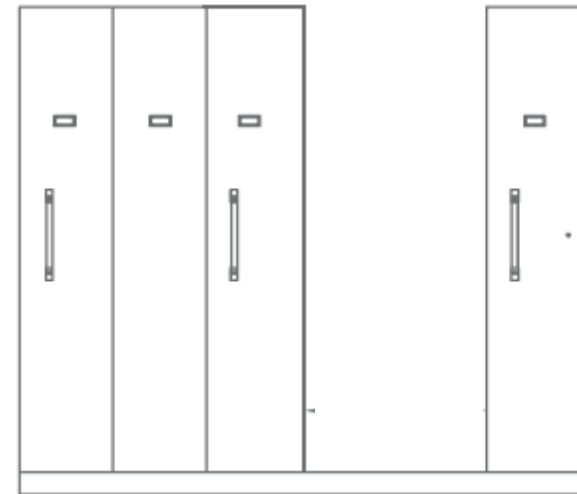
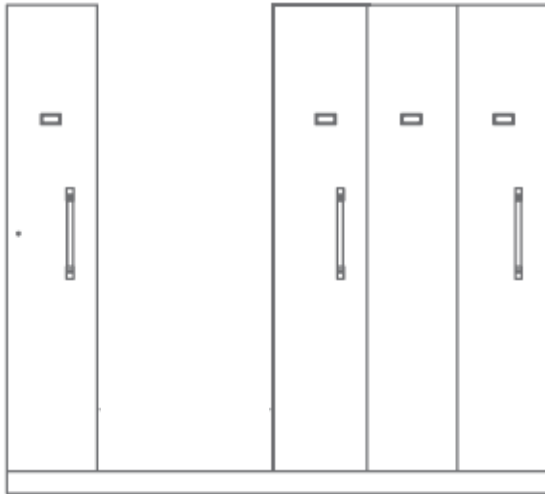

View from left to right

1. Front panel with handle and lock or front panel with handle (the lock position of the shelving unit with lock depends on closing direction, if closing direction is towards the left, then locking unit should be install on the right, if closing direction is towards the right, the locking unit should be install on the left)
2. Front panel with handle
3. Join Front panel to Front panel with handle
4. Front panel

Join the front panel with handle and front panel together

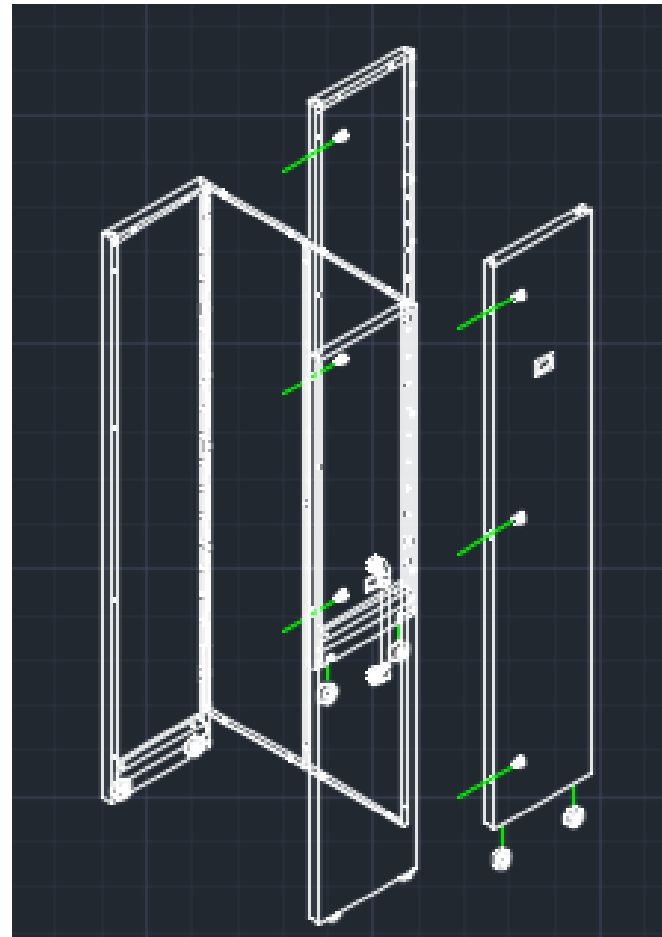
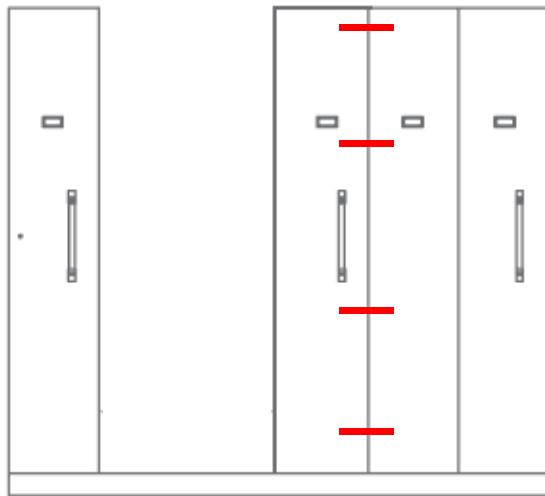

STEP 4 FITTING THE END CAP,
CHIPBOARD AND CHIPBOARD COVER,
SHELVES

- Fit end cap to the tracks

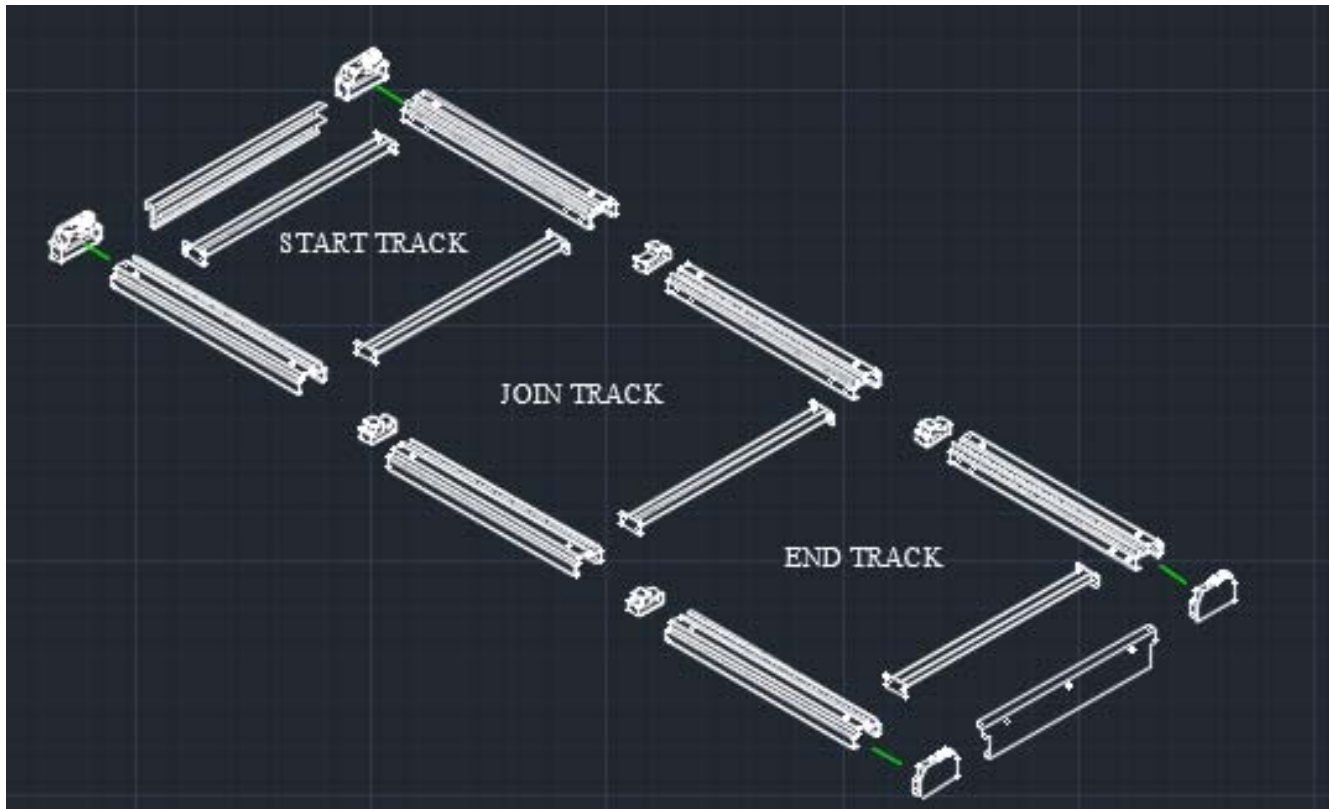

- Cover both side of the tracks with end cap

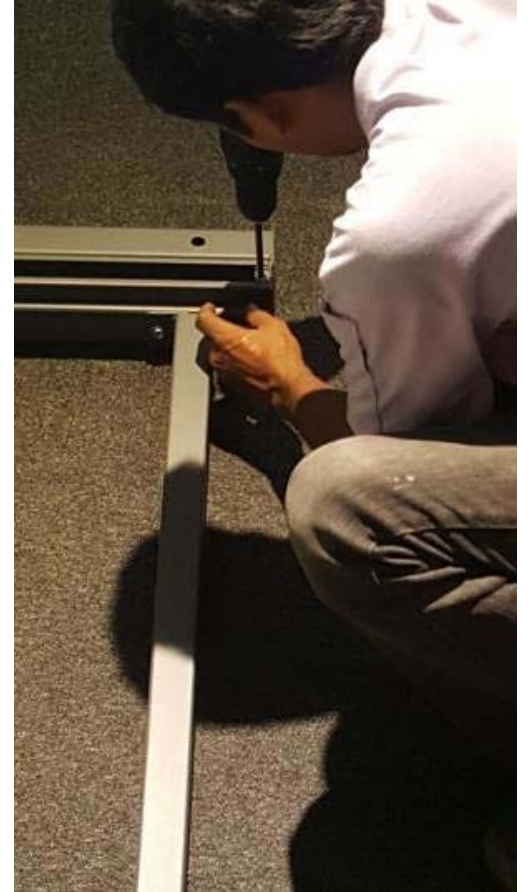



- Place the chipboard on the tracks
- Cover tracks with chipboard
- Cover the end of the chipboard with chipboard cover according the red arrow

- Install Shelves
- Insert H Clip to holes with round middle section
- Below the shelves are holes, fit the shelves to the H clips



STEP 5 LEVELLING AND DRILLING
HOLE FOR LOCK BAR

WINTECH®



- If floor is uneven, adjust levellers so that the compactor platform is levelled
- You can use a screw driver or Deep Socket T-Wrench Size 7/8
- Once completed, drill a hole on the tracks where the central lock is located, the hole is for the central lock's lock bar.

WINTTECH®

Installing Add on

- Each joining shelving unit will be a double unit
- Slot the join track to the join caps to join start track and second join track together
- Install crossbar at the intersection to strengthen the joining of 2 tracks
- Install the second crossbar at the other end

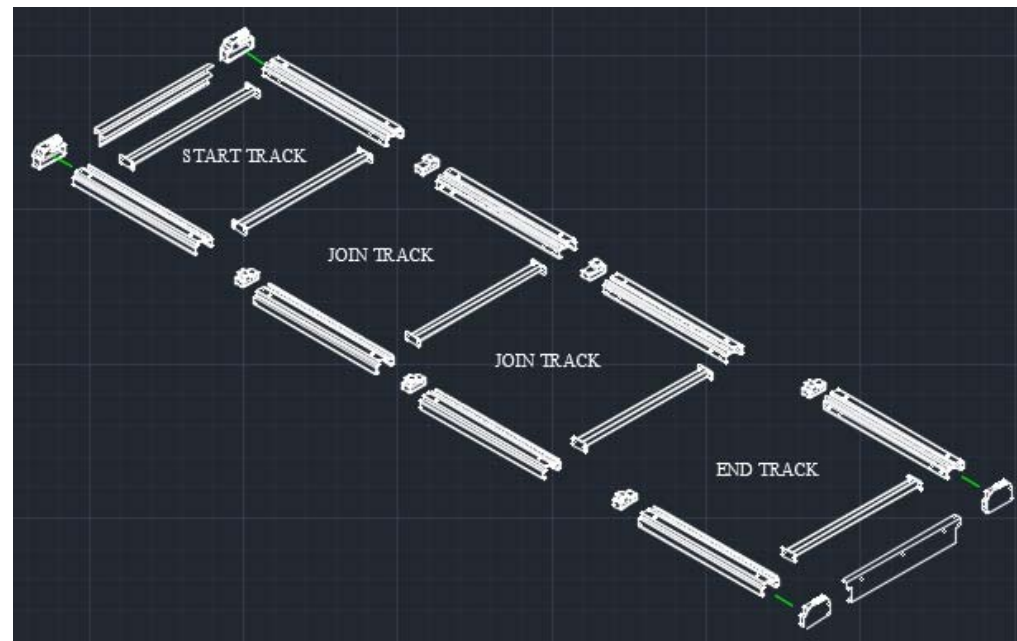

- As for the shelving unit, repeat joining front panel and front panel with handle'
- Joining units are always double bays

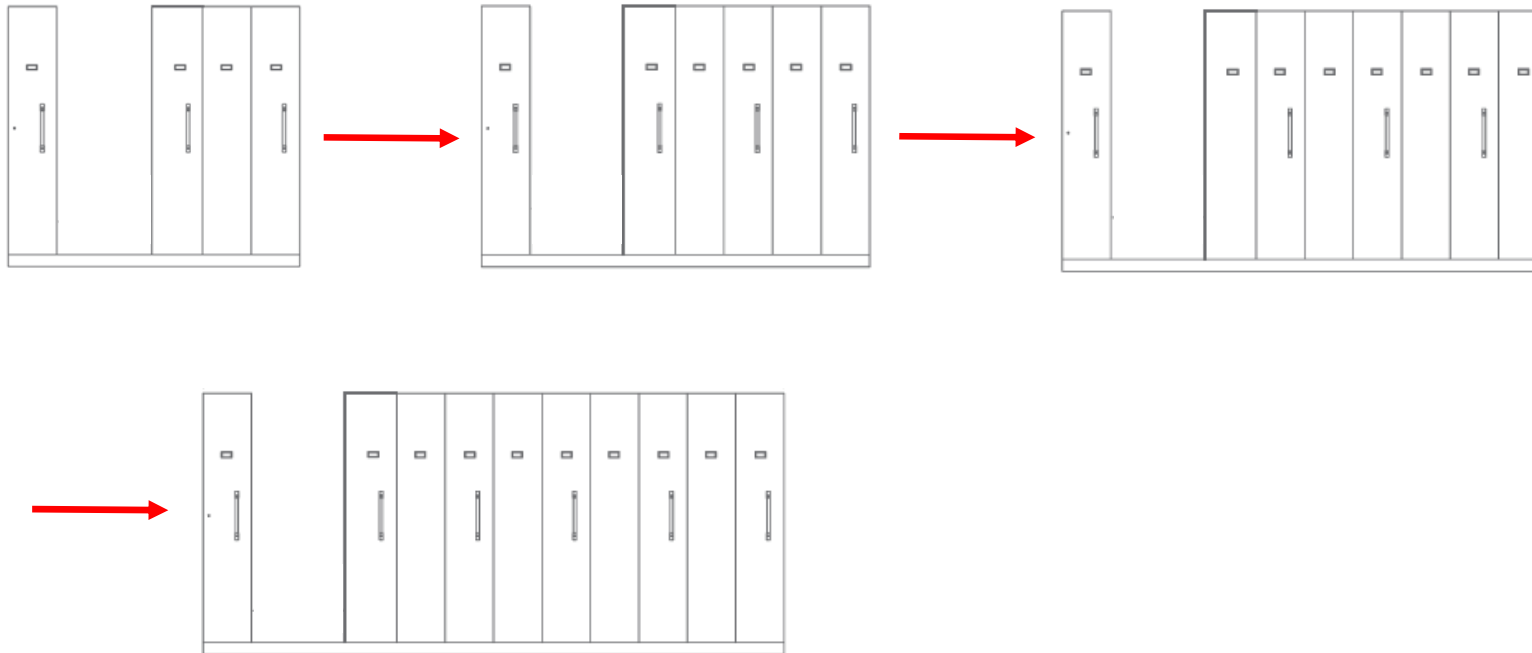

WINTECH®

STANDARD ADD ON INSTALLATION SUMMARY

Things to take note

- Always make sure you have enough room space for the shelving unit
- For installing mobile shelving unit with walls at both side, always ensure a 50mm allowance between the wall and shelving unit



- In case you have to install a mobile shelving unit with walls at both side, install the 1 track and 1 body at a time. Do not install all the tracks first then the body because it will be difficult to insert the body later.
- For instance
 1. install the start track first, then the front panel with handle. Install the front panel with handle to the start track.
 2. Then install the join track and front panel with handle, insert the front panel with handle to the join track. Join the front panel to the front panel with handle.
 3. Install the Front panel with handle, insert front panel with handle to join track.
 4. Lastly the end track

- Installing shelving unit with walls on both side

WINTECH®

